

CHAPTER 3

EXPERIMENTAL METHODS

This chapter gives a detailed description of the experimental system and procedures used in data acquisition and data processing throughout this experiment. Four transducers, labeled orange, blue, yellow, and red were chosen for this study. Table 3.1 gives the nominal parameters of the four transducers.

Transducer	Diameter (cm)	Focal Length (cm)	F-number
orange	6.0	15	2.5
blue	5.5	11	2.25
yellow	5.0	30	6
red	5.0	10	2

Table 3.1 Nominal Parameters for orange, blue, yellow, and red Transducers

The three main parts of the experiment are the characterization, calibration, and water-breaking procedures. A description of each of these will be given in detail. Each part of the three experimental procedures were performed on the four transducers.

The purpose of the characterization procedure is to measure the physical properties of the ultrasound field. These properties include the center frequency (f_c), the -6-dB focal beamwidth, wavelength and the focal length of the ultrasound field.

The purpose of the calibration procedure is to quantify the acoustic pressure at the focus of an ultrasonic transducer. This is done by using a calibrated polyvinylidene fluoride (PVDF) membrane hydrophone (Marconi, Ltd., Essex, England) which has a known calibration factor. This hydrophone has an uncertainty of $\pm 6\%$ in the 1-4 MHz range, and $\pm 8\%$ in the 9-12 MHz range.

The purpose of the water-breaking study is to determine values of the ultrasound field quantities that just break the water-air interface.

3.1 Characterization Procedure

The characterization procedure involves the setup of the equipment, the alignment of the transducer with a reflecting wire, the acquisition of the data, and the processing of the data.

The overall setup of the characterization procedure involves reflecting an ultrasonic pulse off a line target. This is done to obtain a good spatial (axial and lateral) and temporal resolution. In addition, as long as an axisymmetric field distribution can be assumed, only two directions are needed for scanning to obtain a spatial field projection. Using this technique also enables the target size to be varied. The target used is a length of tungsten wire with a diameter of 100 μm (California Fine Wire Company, Grover City, CA). Tungsten wire is chosen because it acts as a reflecting line target. The wire is vertically mounted in a circular acrylic holder which has two screws vertically opposite each other to hold the wire in place. The holder is placed in a tank of distilled, degassed water and attached to a micropositioning system (Daedal Inc., Harrison City, PA). The micropositioning system has five directions: three linear and two rotational. For the following experimental procedures, only the three linear axes will be used. A diagram of the three axes of the micropositioning system that is used is shown in Figure 3.1. The micropositioning system has an accuracy of $\pm 2 \mu\text{m}$.

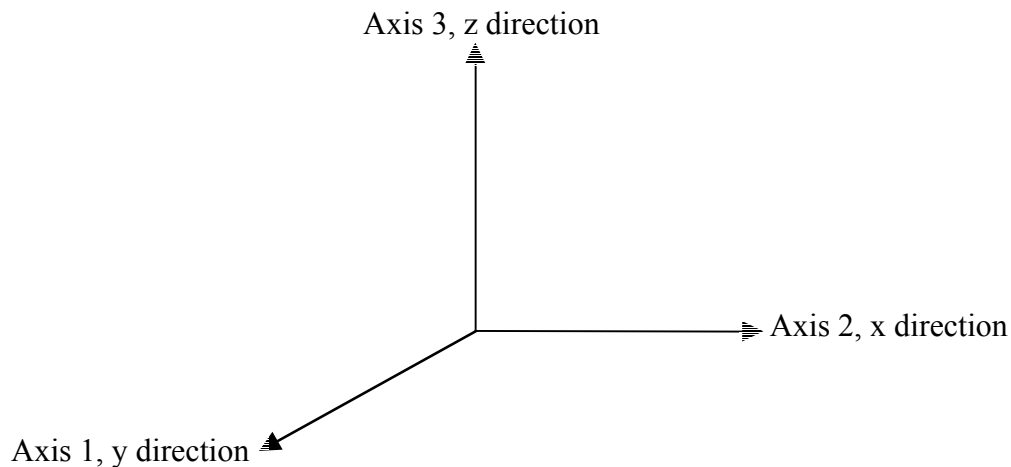

Figure 3.1 Diagram of the x, y, and z Directions and Axes 1, 2, and 3 of the Micropositioning System

The following is a description of the equipment setup. A block diagram of the characterization setup is shown in Figure 3.2. A computer controlled pulser/receiver (Panametrics 5800, Waltham, MA) is connected to and generates a signal to and receives an echo signal from the transducer. The receive signal is amplified by the same pulser/receiver (20 dB for the orange and blue; 40 dB for yellow; 60 dB for red) and band-pass filtered (1-5 MHz for orange, blue, and yellow; 1-20 MHz for red). The micropositioning system, oscilloscope (LeCroy 9354 TM, Chestnut Ridge, NY), and pulser/receiver are connected to a GPIB board and controlled by a computer (Dell Optiplex, Round Rock, TX). The amplified receive signal is displayed on the oscilloscope.

The following is a description of the alignment procedure. First, the transducer to be characterized is manually placed in the large Plexiglas tank, which has the tungsten wire and degassed water. The transducer is positioned such that the sound beam is normal to and reflects off the tungsten wire. Then, the micropositioning system is used to move the tungsten wire in

the axial (Axis 1) and horizontal (Axis 2) directions such that reflection is maximized on the oscilloscope. The position where the reflection is maximized is called the “origin”.

The following is a description of how the data are acquired. First, the nominal beamwidth and depth of focus are calculated. Then, the tungsten wire is moved in the negative axial distance one half of the calculated length for the depth of focus. Then the voltage measurements on the oscilloscope are viewed. At this point, the voltage should be around -20dB of the maximum value. However, if the voltage is not -20dB of this value, the tungsten wire is moved in 1-mm increments in the negative direction until the voltage reaches the desired amplitude. Then the tungsten wire is moved in the positive direction the total amount it was moved in the negative direction. In essence, it is being returned back to the origin. Then the wire is moved in the positive direction the same total amount that it was moved in the negative direction. At this point, the voltage should be around -20dB of the maximum. However, if the voltage is greater, the tungsten wire is moved in 1-mm increments in the positive direction until the voltage reaches the desired amplitude. Then the wire is moved in the negative direction back to the origin. The scan distance in one direction will be the distance in which the wire is moved the greater distance when trying to determine the distance that will decrease the voltage to -20dB of its maximum value. For example, if the wire is moved 3 mm in the positive direction and 5 mm in the negative direction, then the scan distance in one direction would be 5 mm. The total distance that would be scanned when taking actual measurements would be twice that distance, 10 mm. The same procedure is performed in the horizontal direction for the beamwidth. However, the scan distance in the horizontal direction will be much shorter than that in the axial direction. Before starting the actual scan, the tungsten wire is moved from the origin. It is moved in the positive axial direction a length of one axial scan distance. Then, the wire is

moved in the negative horizontal direction a length of one horizontal scan distance. Now, the wire is setup to perform the actual scanning of the acoustic field. The computer is programmed to have the micropositioning system scan in the axial and horizontal distances. The user inputs the scan distances into the computer such that the distance input is twice the scan distance that was measured. Besides programming the total scanning distance, the step size in each direction is programmed as well. The sampling step size in the horizontal and axial direction varies depending upon the transducer frequency. The total scanning distance in the lateral and axial directions are greater than the nominal beamwidth and depth of focus, respectively. This is to ensure that the entire beam is scanned in the lateral and axial directions. The reflections from this wire are displayed on an oscilloscope as a voltage measurement and this data are stored on the same computer which controls the micropositioning system. Then the data are transferred to a workstation (SUN UltraSparc).

The following is a description of the data analysis process. The data that are transferred to the workstation are processed in MATLAB (The Mathworks, Natick, MA) using the ‘complete5.m’ script which is shown in Appendix B [*Raum and O’Brien, 1997*]. The processed data give the measured center frequency, focal length, wavelength and beamwidth. The center frequency is measured by averaging the two frequencies where the acoustic pressure spectrum is -3 dB of its maximum value. This is determined from the RF-signal at the true focal point. All the transducers in this study were characterized using this “pulse-echo field distribution measurement” technique.

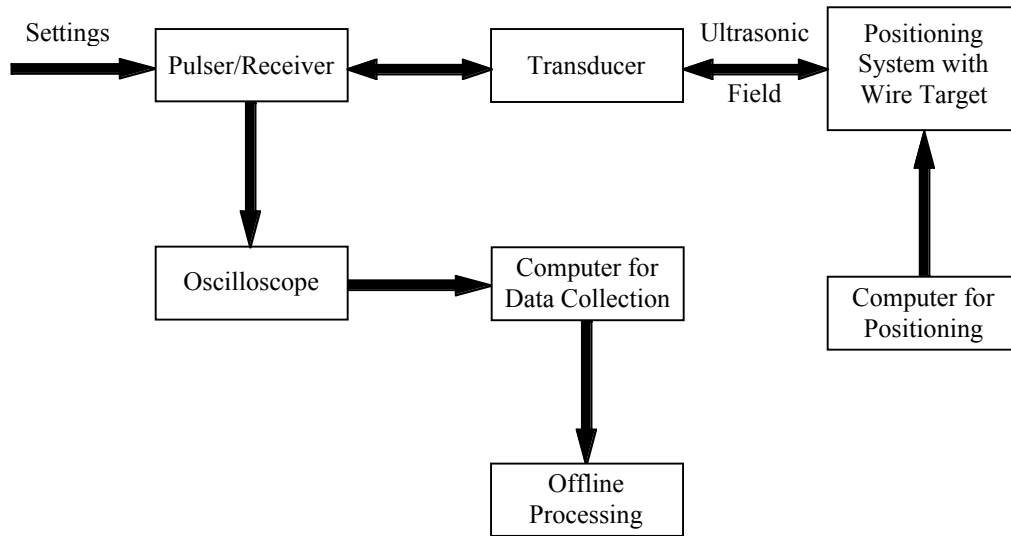

Figure 3.2 Block diagram of the Characterization Setup

When performing a characterization, the beam field is mapped and an intensity profile is displayed. A typical beam profile is displayed in Figure 3.3, where the lightest colored regions represent the highest intensity.

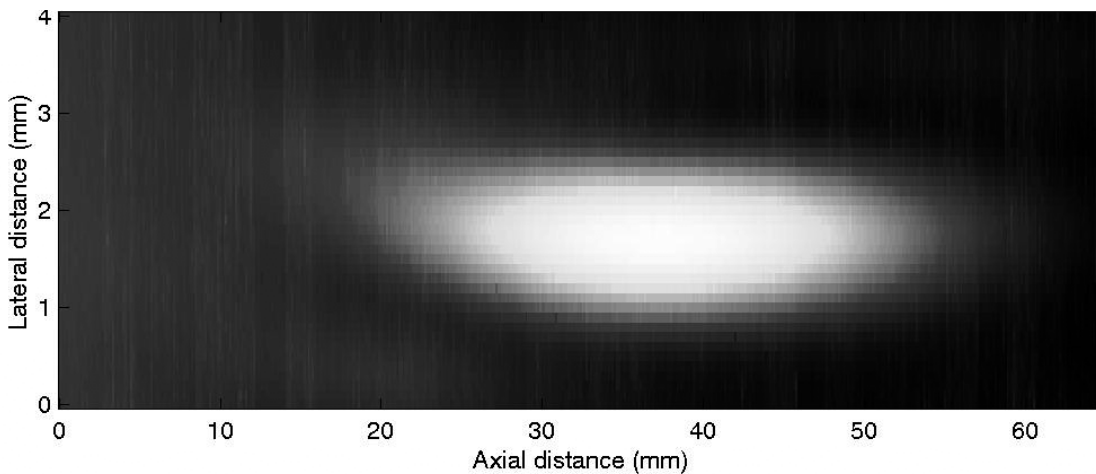

Figure 3.3 Typical Beam Profile

The intensity profiles for all four transducers are displayed in Figure A.1-A.4. Figure A.1 is the beam profile for the blue transducer. Figure A.2 is the beam profile for the orange transducer. Figure A.3 is the beam profile for the yellow transducer. Figure A.4 is the beam profile for the red transducer. The entire beam profile for the yellow transducer was not mapped

entirely. A cropped version of the beam axis is shown in figure A.3. The information obtained from this beam profile was satisfactory. Thus, another characterization was not necessary.

3.2 Water-Breaking Study Procedure

The “Water-Breaking” procedure is designed to determine the threshold ultrasonic field quantity required to just break a water-air boundary and the corresponding distance between the surface of the transducer and the water-air boundary at which this breakage occurs.

The water-breaking study is done under two cases. They are continuous and pulsed wave. A continuous wave is an ultrasonic wave which is continually transmitting. A pulsed wave is an ultrasonic wave that is transmitting a short ultrasonic burst periodically. The period in which an ultrasonic wave is transmitted is specified in the form of a frequency or time period, known as the pulse repetition frequency (PRF) or pulse repetition period (PRP). This was discussed briefly in Chapter 2. These two setups will be described in detail.

First, a transducer is submerged in distilled, degassed water at a depth greater than the focal length which was determined by the characterization procedure. However, this only applies to the red and yellow transducers which have a flat bottom casing. For the blue and orange transducers, the transducer is placed in a stationary holder. The holder is made of a Rubbermaid™ cylindrical shaped container, with the bottom cut out. The transducer and holder are submerged in distilled, degassed water at a depth greater than the focal length which was determined from the characterization procedure.

For all transducers, the ultrasonic beam is focused up and onto the water-air boundary. The beam is focused such that it is normally incident to the water-air boundary. The transducer is powered by a power amplifier [ENI A-500 RF Power Amplifier (0.3-35 MHz, 60 dB),

Rochester, NY] which is controlled in one of three ways by a function generator. The three different approaches to the setup of the function generator are:

- i. Function Generator with “Internal Burst” mode
- ii. Function Generator and Attenuation Bar
- iii. Two Function Generators with a Double Balance Mixer

The approach taken depended on the type of waveform (continuous or pulsed) desired as well as the transducer frequency.

3.2.i Function Generator with “Internal Burst” mode

The Function Generator with “Internal Burst” [Hewlett-Packard 8116A Pulse/Function Generator (50 MHz), Germany] mode is a direct method to create a sinusoidal continuous wave or a pulsed wave. This function generator has a built in burst function which allows for the pulsed wave. A block diagram of the setup is shown in Figure 3.4.

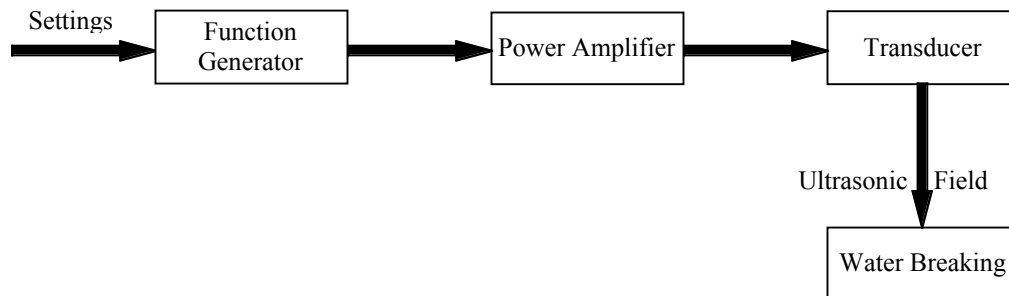

Figure 3.4 Block Diagram of the “Water-Breaking” Setup Using the Function Generator with the “Internal Burst” Mode

For the continuous wave case, the function generator settings are set to ‘sinusoidal continuous wave’ and the center frequency is set to the center frequency which is obtained from the characterization data of the particular transducer.

For the pulsed condition, the function generator settings are set to the “internal burst” mode and the pulse repetition period is changed to 2 ms or 1 ms which is the equivalent pulse

repetition frequency of 500 Hz or 1 kHz, respectively. A pulse repetition frequency of 500 Hz and 1 kHz are chosen because in previous experiments [O'Brien *et al.*, 2001], [O'Brien *et al.*, 2003]; these values were used when testing to determine if and how the pulse repetition frequency affects lung hemorrhage. However, the yellow transducer was unable to break the water surface with a pulse repetition frequency of 500 Hz or 1 kHz. For this transducer only, pulse repetition frequencies of 9 kHz and 11 kHz are used. These pulse repetition frequencies are the equivalent of .1 ms and .09 ms, respectively. Like the continuous wave case, the center frequency is set to the measured center frequency obtained from the characterization data and the duty cycle is set to 50%.

3.2.ii Function Generator and Attenuation Bar

This setup is somewhat similar to the setup described in Section 3.2.i. However, the function generator [Hewlett-Packard 33120 Function/Arbitrary Waveform Generator, Germany] used in this setup has a minimum acoustic field quantity which is greater than that required to just break the water-air boundary. Thus, an attenuation bar [93 Ohms Attenuation Bar, Arenberg Ultrasonic Laboratory, Boston, MA] is used to decrease the acoustic field quantity. A block diagram of this setup is shown in Figure 3.5. The settings for the continuous and pulsed waves are the same as that in Section 3.2.i.

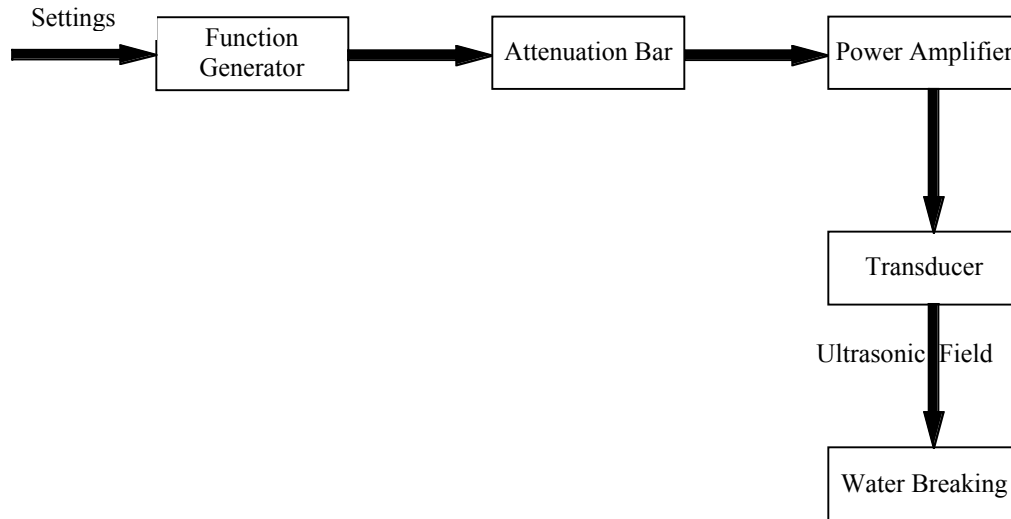

Figure 3.5 Block Diagram of the “Water-Breaking” Setup Using the Function Generator and Attenuation Bar

3.2.iii Two Function Generators with Double Balance Mixer

The concepts behind this setup are similar as Setup 3.2.i and 3.2.ii. However, this setup involves two function generators [Hewlett-Packard 8116A Pulse/Function Generator (50 MHz), Germany] and a double balance mixer [Mini-Circuits ZFM, Branson, MO]. This setup is used for pulsed waves that have a transducer center frequency greater than 5 MHz. The function generator used in Section 3.2.ii is not capable of producing pulsed waves for center frequencies greater than 5 MHz. Therefore, the two function generators and double balance mixer are used in place of the single function generator in part 3.2.i and the function generator with the attenuation bar in part 3.2.ii. The purpose of the double balance mixer is to generate a pulse from a continuous wave signal. A figure of this setup is shown in Figure 3.6.

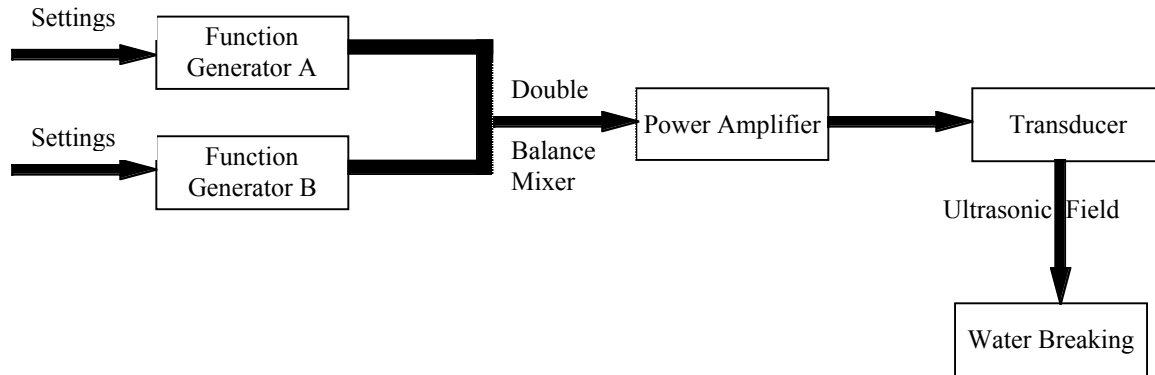

Figure 3.6 Block Diagram of the “Water-Breaking” Setup Using Two Function Generators with the Double Balance Mixer

The first function generator will be called function generator A and the second, function generator B. The purpose of function generator A will be to generate a sinusoidal continuous wave. The center frequency and the driving voltage are inputted into this function generator. To make the continuous wave a pulsed wave, function generator B is used. Function generator B produces a square wave to create a pulse and the pulse repetition period is changed on the function generator B to match that of either the continuous wave or the pulsed wave case. Function generator A is connected to the “input voltage” side of the double balance mixer with a BNC cable and function generator B is connected to the “trigger” side of the double balance mixer with a BNC cable. A third BNC cable is connected from the output of the double balance mixer to the power amplifier. The settings for the continuous and pulsed waves are the same as that in Section 3.2.i.

For the continuous and pulsed wave case of all the methods described above (Sections 3.2.i-3.2.iii), the lowest possible voltage setting, 10 mV, is tested first to determine if the water-air boundary is broken. The voltage is increased in 0.1 mV increments and tested again to determine if the water-air boundary is broken. This is repeated until the water-air boundary is

broken. The definition of the water-air boundary being broken is when there is visible evidence that the surface tension of the water has broken and is shown in Figure 3.7.



Figure 3.7 Water-Air Boundary Broken at Threshold

The minimum water-breaking voltage required is recorded and the corresponding distance from the transducer surface to the water surface is measured and recorded with the water-breaking voltage setting. The distance between the transducer and water surface is decreased by 1 mm and the minimum water-breaking voltage is determined and recorded with the distance once again. This process of decreasing the distance by 1 mm increments and determining the water-breaking voltage is repeated until the depth of the water is less than that of the focal length. This is indicated by a rise in the water-breaking voltage as the water depth continues to decrease. After the measurements are taken, each of the pairs of water-breaking voltage and distance between the water surface and transducer surface are graphed using Microsoft Excel (Microsoft Corporation, Redmond, WA). The distance between the transducer and the water surface is plotted on the x axis and the water-breaking voltage on the y axis. A typical graph would look like Figure 3.8.

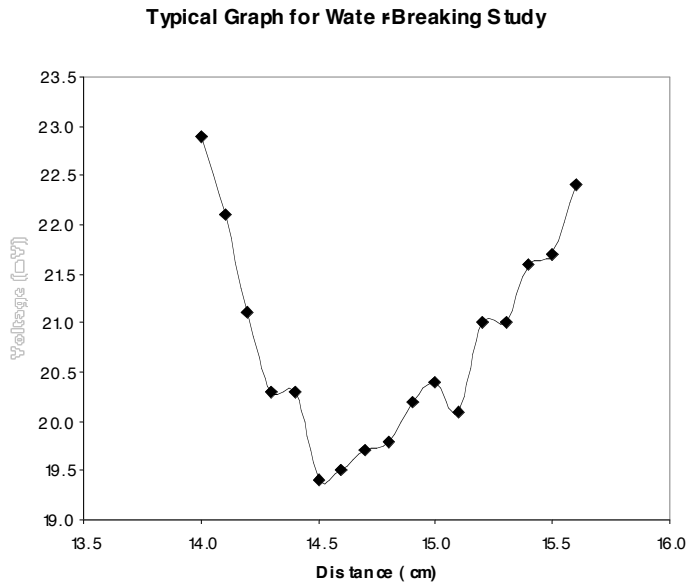

Figure 3.8 Typical Graph for the Water-Breaking Study

From this graph in Figure 3.8, the water-breaking length and corresponding water-breaking voltage can be determined. To determine the water-breaking length, note on the y axis of the Excel graph where the water-breaking voltage is at a minimum and find the corresponding distance on the x axis. This is because the beamwidth is smallest where the least amount of energy is required to break the water-air boundary and the smallest beamwidth corresponds to the focus. At distances greater and less than the focal length determined from this procedure, the required water-breaking voltage is greater.

3.3 Calibration Setup

The purpose of the calibration procedure is to determine the peak rarefactional pressure (p_r), the peak compressional pressure (p_c), and the pulse intensity integral (PII). From the PII, radiation force can be calculated. The three approaches (3.2.i-3.2.iii) used in Section 3.2 are also used in determining the above information. These three approaches are

- i. Function Generator with “Internal Burst” mode
- ii. Function Generator and Attenuation Bar

iii. Two Function Generators with Double Balance Mixer

The calibration procedure involves a few steps. The basic steps involved in each approach above are the setup of the equipment, the alignment of the transducer with the hydrophone, the acquisition of the data, and the processing of the data. The difference between these three methods is in the setup of the equipment. The setup of the function generator equipment in each of the following sections is exactly the same as the setup in the previous sections (Sections 3.2.i-3.2.iii). The alignment of the transducer with the hydrophone, the data acquisition, and data processing are the same. In the following sections, the equipment setup, specifically the procedure to drive the transducer, will be described and at the end of this chapter, the alignment of the transducer with the hydrophone, the data acquisition, and the data processing will be described.

3.3.i Function Generator with “Internal Burst” mode

The Function Generator with “Internal Burst” mode method is a direct method used to measure the voltage, convert it to pressure and calculate the intensity.

The settings for the function generator should be set to replicate those in the water-breaking study. However, the calibration procedure is performed under pulsed wave conditions. In order to assume continuous wave conditions, the burst count, or the number of cycles must be significantly long such that the sinusoidal wave is able to reach steady state and the pulse repetition frequency must be small enough so that the repeated pulses do not interfere with one another. The number of cycles varies by transducer. The orange transducer is set to a burst count of 45 cycles, blue is set 40 cycles, and yellow and red are both set to 35 cycles. For the pulsed wave condition, the pulse repetition frequency is set to 1 kHz. This pulse repetition frequency is small enough such that the repeated pulses do not interfere with one another. A

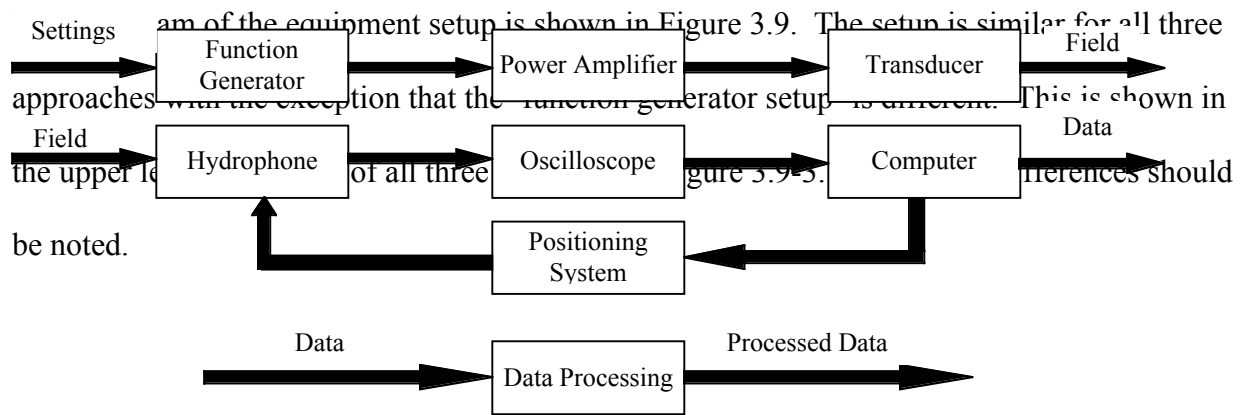

Figure 3.9 Block Diagram of the Calibration Setup with “Internal Burst Mode”

3.3.ii Function Generator and Attenuation Bar

The main objective and concepts behind this setup is similar to the previous setup. A diagram of this setup is shown in Figure 3.10. In this setup, the same function generator used in 3.2.ii is used. The lowest voltage setting this function generator is capable of under the internal bursting mode condition at a pulse repetition frequency of 500 Hz or 1 kHz is 50 mV. However, the voltage values that the transducer is calibrated at are lower than 50 mV. Therefore, an attenuation bar is used to obtain the desired voltage. The function generator settings are set to a sinusoidal wave and internal bursting mode with a carrier frequency of the center frequency of the transducer. Similar to part 3.3.i, the function generator is set to a pulse repetition frequency of 1 kHz and a burst count significantly long that the waveform is able to reach steady state for the continuous wave case. The burst count for the orange transducer is set to 45 cycles, 40 cycles for blue, and 35 cycles for the yellow and red transducers, which is the same as that for

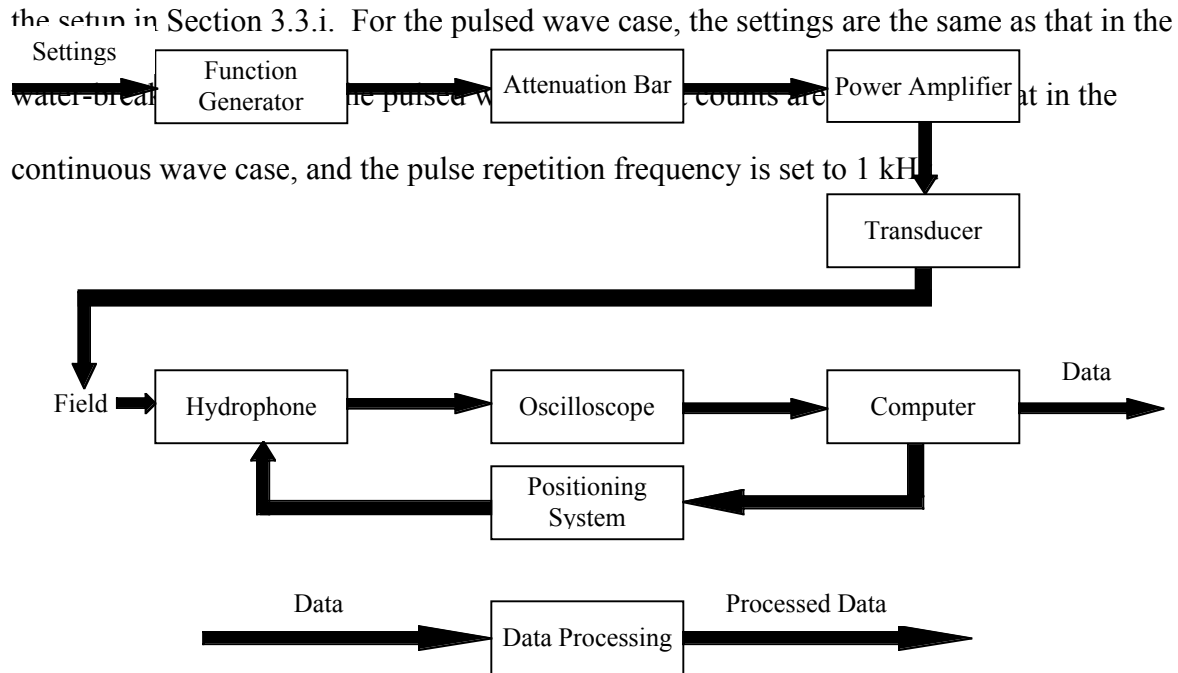

Figure 3.10 Block Diagram of the Calibration Setup with the Attenuation Bar

3.3.iii Two Function Generators with Double Balance Mixer

This setup is similar to the previous two setups. A diagram of this setup is shown in Figure 3.11. In this setup, the two function generators and the double balance mixer which are used in Section 3.2.iii are used in place of the single function generator in part 3.3.i and the function generator with the attenuation bar in part 3.3.ii. The function generators and double balanced mixer are setup in the same way as explained in Section 3.2.iii. The amplitude of the trigger can also be changed and is set at 1.7 V. This was chosen because the amplitude of the trigger waveform in Section 3.3.i and 3.3.ii was examined and the amplitude was found to be approximately 1.7 V. Similar to Section 3.2.iii, function generator A is connected to the “input voltage” side of the double balance mixer with a BNC cable and function generator B is

connected to the “trigger” side of the double balance mixer with a BNC cable. A third BNC cable is connected from the output of the double balance mixer to the power amplifier. From here, the rest of the experiment is similar to that of Section 3.3.i and 3.3.ii.

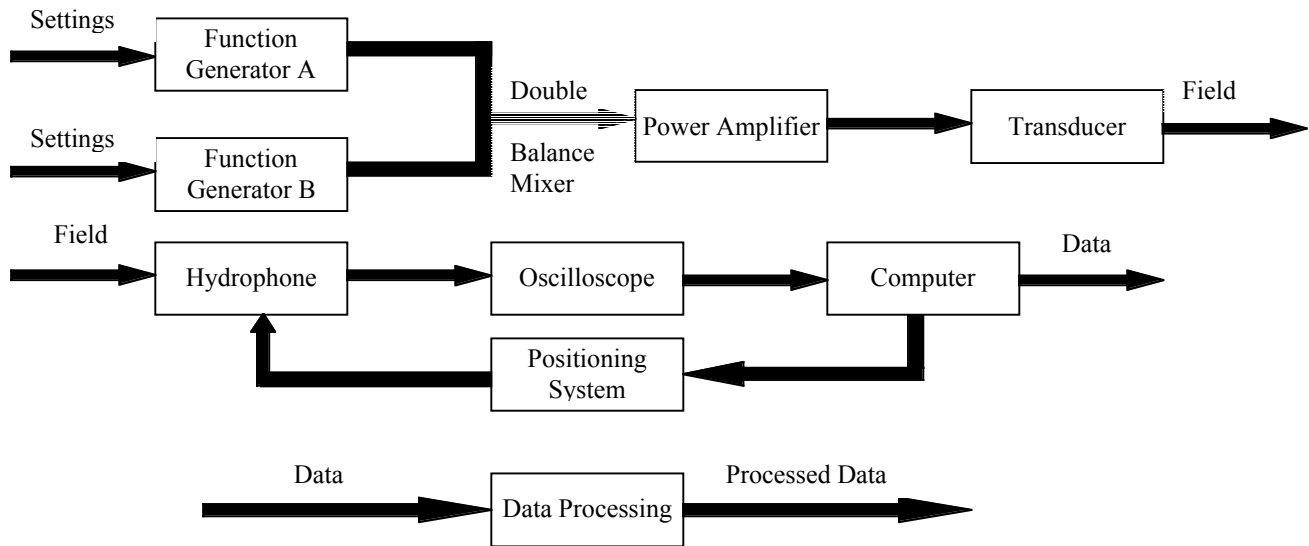

Figure 3.11 Block Diagram of the Calibration setup with the Double Balance Mixer

The following procedures apply to all three approaches. The overall measuring concepts in the calibration section are similar to those in the characterization section. However, instead of using a wire line target as a reflector, a Marconi hydrophone is used to measure the signal from the transducer [Sempstrott, 2000]. In addition, the Marconi hydrophone is moved axially [Axis 1], horizontally [Axis 2], and vertically [Axis 3] to measure the beam field.

First, a Plexiglas tank is filled with distilled, degassed water and a transducer and hydrophone are placed in the tank with the hydrophone attached to the micropositioning system. The ultrasound beam is manually focused such that the beam is normal to the hydrophone. The driving signal to the transducer can be produced in one of three ways. These three ways are explained above (3.3.i-3.3.iii).

The output of the function generator is connected to the input of the power amplifier with a BNC cable. The output from the power amplifier is connected to the transducer with another BNC cable. The trigger output from the function generator is connected to the channel on the oscilloscope which is set to be the trigger. For this experiment, the trigger output is connected to channel 3 and in the trigger setup menu of the oscilloscope, it is set to trigger on channel 3.

The transducer and hydrophone are then aligned such that the beam axis is normal to the hydrophone and a maximum voltage signal is obtained on the oscilloscope. The transducer and hydrophone are first aligned manually to obtain a coarse, visual alignment. Next the micropositioning system is used to move the hydrophone in the axial, horizontal, and vertical directions to obtain a maximum voltage. Occasionally, the beam from the transducer may not be normal to the hydrophone. In this case, either the transducer or hydrophone may need to be rotated slightly. Once a maximized signal is obtained, this will be called the “origin” and assumed to be the focus.

The signal obtained by the hydrophone is sent to a preamplifier, which is powered by a power supply [Hewlett-Packard 6236B Triple Output Power Supply, Germany] and connected to the oscilloscope by a BNC cable. The amplified signal is displayed on the oscilloscope as a voltage.

Now, the size of the field to be scanned needs to be determined. This procedure is somewhat similar to the characterization procedure where the wire was moved away from the origin in both the positive and negative direction. The hydrophone is moved from the origin axially in the negative direction. However, unlike the characterization, where the wire is moved off axis until the signal is zero, the hydrophone is moved from the origin until the signal is about half of what it is at the origin. Then the hydrophone is moved in the positive direction back to

the origin and from there, it is moved to a distance positive from the origin. This distance is the same distance that the hydrophone is moved in the negative direction. In essence, the hydrophone is being moved twice the distance in the positive direction that it was moved in the negative direction. At this distance, it needs to be determined if the signal on the oscilloscope is about half of what it is at the origin.

If the amplitude of the signal is more than half of what it was at the origin, then there are two options. The first option is to increase the distance from the origin until the amplitude of the signal is about half. The second option is to realign the hydrophone and transducer. When deciding which option to choose, the amplitude of the signal is examined and it is decided if it is close to half of the voltage at the origin. If it is, perform the first option. If the signal is much greater than half, then perform the second option.

If the amplitude of the signal is about half, record the distance the hydrophone is moved from the origin. Next, determine the distance to be scanned in the horizontal and vertical directions. The distance to be scanned in the other two directions (horizontal and vertical) can be determined in the same way that the axial distance is determined. One requirement is that the horizontal and vertical distances to be scanned have to be the same.

Next, the hydrophone will be moved in preparation to scan the acoustic field. First, the hydrophone will be moved in the positive axial direction the distance that was determined above. Then it will be moved in the negative horizontal and vertical directions the distance that was determined above as well. The distances moved are those that decrease the amplitude by half.

Now, the field is ready to be scanned. At this point, the temperature of the water and the time at which the signal begins are measured. The temperature is measured to determine the speed of propagation which is used to determine the distance between the transducer and

hydrophone. The field is axially, horizontally, and vertically scanned twice the distance that was discussed above. This scanning process is automated.

The distances chosen to scan the field are such that there is a clear indication that the maximum voltage is obtained on the oscilloscope sometime during the scan. This means that the greatest voltage would be seen on the scope when all three axes are aligned with the hydrophone. When the greatest voltage is seen on the scope, the transducer is in focus with the hydrophone. The step size used to scan the field is determined by ensuring it is less than one quarter of the wavelength and it divides evenly into the total distance to be scanned. This varies between transducers because they have different frequencies, thus different wavelengths. The data from the scan are collected on the Dell Optiplex then transferred to a workstation for offline processing.

The data are analyzed offline using Matlab software. The program in Matlab uses the voltage and a pre-determined calibration factor for the particular hydrophone to determine the pressures and voltage intensity integral. The program used is called 'complete5.m' and can be found in Appendix C.

The driving voltage is varied in this experiment and is determined by the voltages obtained from the water-breaking data. The minimum water-breaking voltage is determined and the voltages above and below it were bracketed in 5 mV increments. The voltage range varies between transducers and by the pulse repetition frequency.